



Curb and Gutter Section

Proposed R/W should be set at a dimension that encompasses the berm and protects the clear zone. For a curb and gutter section posted at 45 mph, the clear zone is defined as 12 feet. All new or relocated utility poles shall be placed at or just outside the R/W and consequently beyond the 12 foot clear zone. For a curb and gutter section posted at 35 mph, the clear zone is defined as 10 feet. All new or relocated utility poles shall be placed at or just outside the R/W and consequently beyond the 10 foot clear zone. For a curb and gutter section posted at 25 mph, the clear zone is defined as 8 feet. All new or relocated utility poles shall be placed at or just outside the R/W and consequently beyond the 8 foot clear zone. A PUE may be provided beyond the proposed R/W to encompass the utility poles and preferably along only one side of the highway. Please see the table below and the attached sketches.

Posted Speed Limit	Clear Zone with Curb and Gutter
45 mph	12 ft.
35 mph	10 ft.
25 mph	8 ft.

Site specific constraints such as insufficient R/W available, prohibitive slopes and other factors may make implementation of the full clear zone not feasible. In such cases good engineering judgment should be used. Relocated and new utility poles should be placed as far as practical from the roadway, consistent with other fixed objects along the subject road. The Proposed Design Criteria sheet created by the roadway design engineer for each TIP project will list the appropriate clear zone. During the planning stages for TIP projects, consideration should be given to the need for additional R/W and PUE for the placement of utility poles.

This memo supersedes Debbie Barbour's memo dated December 10, 2003 to Jay Bennett and Victor Barbour with the subject of Utility Pole Placement. This memo uses findings and conclusions presented in the technical report from the Center for Transportation Research and Education titled "Clear Zone – A Synthesis of Practice and an Evaluation of the Benefits of Meeting the 10 ft Clear Zone Goal on Urban Streets", authored by Thomas Maze, Christian Sax and Neal Hawkins. Supplementary notes of this report can be found at [www.ctre.iastate.edu](http://www.ctre.iastate.edu). Please begin using these guidelines immediately on all TIP and other applicable projects. If anyone should have any questions, please contact Dewayne Sykes at (919) 250-4128 or [dsykes@ncdot.gov](mailto:dsykes@ncdot.gov) or Jay Bennett at (919) 250-4016 or [jbennett@ncdot.gov](mailto:jbennett@ncdot.gov).

DLS/JAB

Attachments

cc: Terry Gibson, PE  
Deborah Barbour, PE  
Kevin Lacy, PE  
Virgil Pridemore  
Division Engineers  
Roadway Design Project Engineers  
Utility Squad Leaders  
✓ Glenn Mumford, PE  
Roger Thomas, PE  
Greg Thorpe, PhD  
Jon Nance, PE  
Victor Barbour, PE  
Roger Worthington, PE  
DDC Engineers  
Robert Memory  
Utility Area Agents  
Doug Taylor, PE  
Ron Hancock, PE

# SHOULDER SECTION

w/ FULL & LIMITED CONTROLLED ACCESS

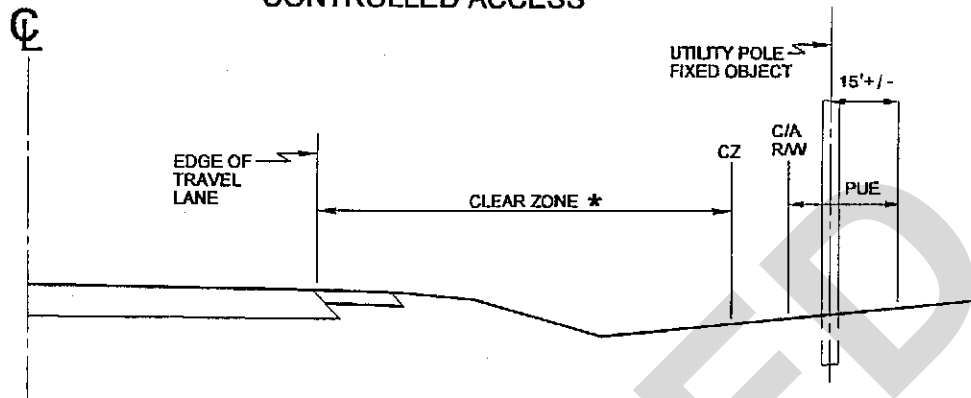

UTILITY POLE PLACED OUTSIDE CLEAR ZONE & RIGHT OF WAY  
\*AS DEFINED BY THE MOST CURRENT AASHTO ROADSIDE DESIGN GUIDE

# SHOULDER SECTION

w/ PARTIAL OR NO CONTROLLED ACCESS

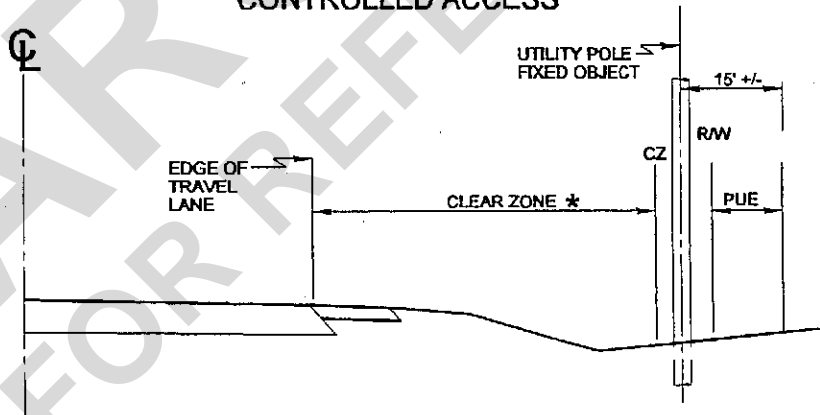

UTILITY POLE PLACED OUTSIDE CLEAR ZONE BUT NOT NECESSARILY  
OUTSIDE RIGHT OF WAY  
\*AS DEFINED BY THE MOST CURRENT AASHTO ROADSIDE DESIGN GUIDE

# CURB & GUTTER SECTION

(POSTED AT 45 MPH)

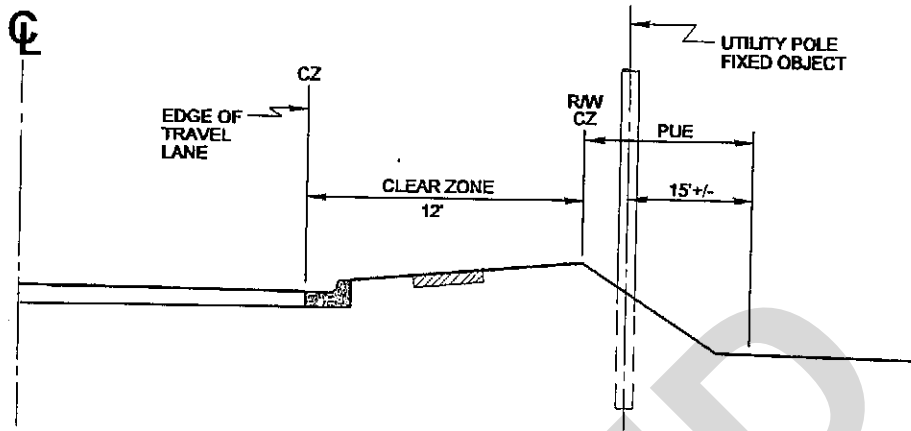

UTILITY POLE PLACED OUTSIDE 12' CLEAR ZONE, SIDEWALK & RIGHT OF WAY

# CURB & GUTTER SECTION

(POSTED AT 35 MPH)

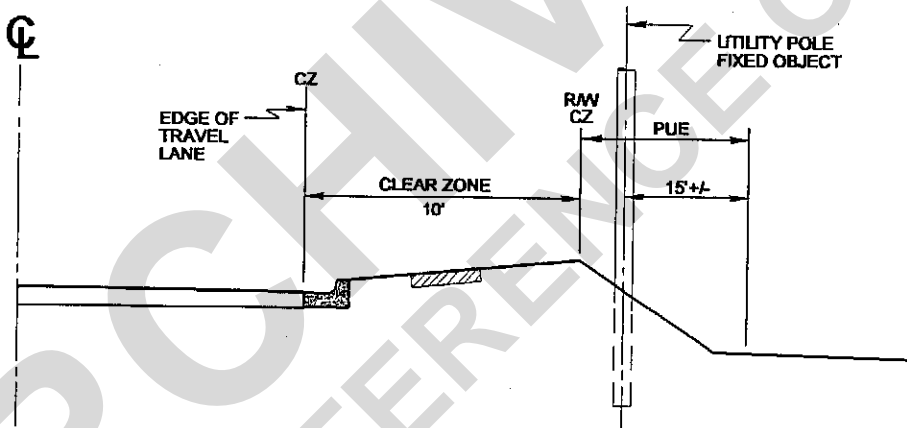

UTILITY POLE PLACED OUTSIDE 10' CLEAR ZONE, SIDEWALK & RIGHT OF WAY

# CURB & GUTTER SECTION

(POSTED AT 25 MPH)

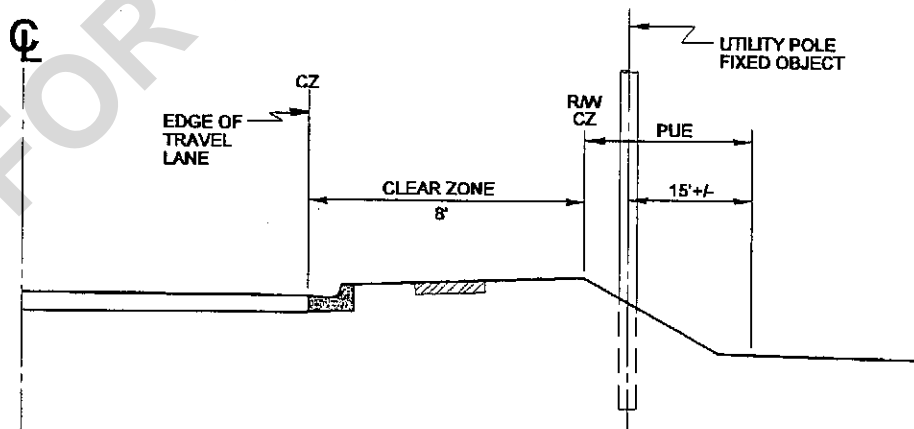

UTILITY POLE PLACED OUTSIDE 8' CLEAR ZONE, SIDEWALK & RIGHT OF WAY